

## GNM 26 - GP 48.2

**DC**  
**Geared Motors**  
with permanent magnet field

Motor series GNM 26  
with + without parking brake  
Planetary gear series GP 48.2  
**up to 20 Nm**

Designs with brake with 1000mm connection cord

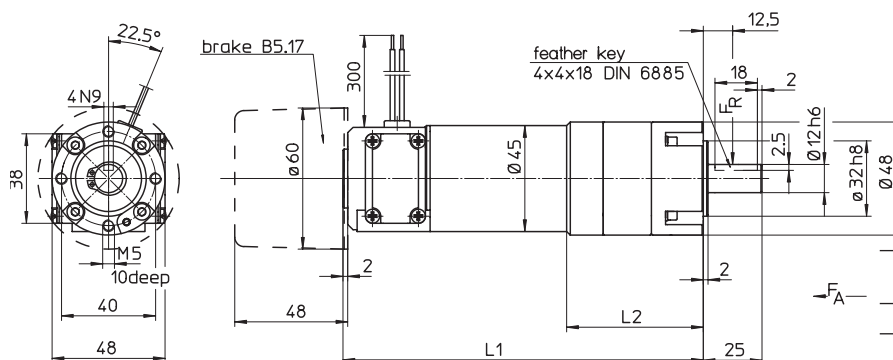

Type	Gear Ratio	Dimension	
		L1	L2
GNM 2636A	180:1 - 450 :1	187,5	91,5
GNM 2670A	5:1 - 7,66:1	198	58
GNM 2670A	21:1 - 59 :1	214,5	74,5
GNM 2670A	94:1 - 150 :1	231,5	91,5

type	GNM 26 - GP 48.2		
series	A		
operation acc. to standards VDE 0530	S1		
isolation acc. to standards VDE 0530	F		
protection acc. to standards VDE 0530	IP 41		
kind of connection	free leads		
rotating direction	reversible		
bearing (motor and gear box)	ball bearing		
gear box	not self-locking		
<b>parking brake B 5.17</b>			
nominal voltage	V	24	
nominal current	A	0,3	
static brake torque (motor shaft)	Nm	0,5	
max. number of operations/h		2000	

- Motors also available with DC-tachometer and/ or incremental encoder
- Motors also available in protection IP 54 and/ or with device plug DIN 43650
- Design with brake in protection IP 54 and with cable connection

### Motor design:

Brush holder opening will be accessible by removing the cover plate.

Flange mounting with 4 threads, see drawing.

Rotating direction:

The rotating direction can be changed by inverting the connections.

1. Order example

Motor - gear box  
GNM 2670A - GP 48.2  
24 V, 3000 rpm - 5:1

2. Order example

Motor - parking brake - gear box  
GNM 2670A - B 5.17 - GP 48.2  
24 V, 3000 rpm - 24 V - 25:1

Special designs on request.

**GNM 26 - GP 48.2**

1 nominal voltage	2 nominal speed	3 nominal torque	4 starting torque	5 nominal torque at undulatory current	6 nominal power	7 nominal current	8 nominal current at undulatory current	9 peak current	10 power gear box input	11 nominal speed gear box input	12 ratio gear box	13 efficiency gear box	load limitations gear box			17 max. backlash	18 moment of inertia gear box <sup>1)</sup>	19 total weight motor + gear box	20 total weight motor + gear box + parking brake	21 F <sub>k</sub> (allow. radial shaft load) <sup>2)</sup>	22 F <sub>A</sub> (allow. axial shaft load)	23 Motor type	
													14 max. power	15 max. cont. torque	16 max. starting torque								
V	rpm	Nm	Nm	Nm	W	A	A	A	W	rpm	i	%	W	Nm	Nm	< min	kgm <sup>2</sup>	kg	kg	N	N		
24	600	0,57	1,7	0,37	36	2,6	1,8	12	40	3000	5 :1	90	63	1,0	3,0	80	0,00017x10 <sup>-3</sup>	1,32	1,55	112	100	GNM 2670A	
24	500	0,69	2,0	0,44	36	2,6	1,8	12	40	3000	6 :1	90	68	1,3	3,5	80	0,00012x10 <sup>-3</sup>	1,32	1,55	112	100		
24	392	0,88	2,6	0,57	36	2,6	1,8	12	40	3000	7,66:1	90	41	1,0	3,0	80	0,00007x10 <sup>-3</sup>	1,32	1,55	112	100		
24	143	2,3	7,0	1,5	34	2,6	1,8	12	40	3000	21 :1	85	48	3,2	12	50	0,00015x10 <sup>-3</sup>	1,51	1,74	150	110		
24	120	2,7	8,4	1,8	34	2,6	1,8	12	40	3000	25 :1	85	50	4,0	14,5	50	0,00014x10 <sup>-3</sup>	1,51	1,74	150	110		
24	100	3,2	10	2,1	34	2,6	1,8	12	40	3000	30 :1	85	50	4,8	14,5	50	0,00010x10 <sup>-3</sup>	1,51	1,74	150	110		
24	83	3,9	12	2,5	34	2,6	1,8	12	40	3000	36 :1	85	48	5,5	16	50	0,00010x10 <sup>-3</sup>	1,51	1,74	150	110		
24	65	5,0	15	3,2	34	2,6	1,8	12	40	3000	46 :1	85	38	5,6	16	50	0,00006x10 <sup>-3</sup>	1,51	1,74	150	110		
24	51	6,0 <sup>3)</sup>	16 <sup>3)</sup>	4,1	32	2,5 <sup>3)</sup>	1,8	9,8 <sup>3)</sup>	38	3000	59 :1	85	32	6,0	16	50	0,00006x10 <sup>-3</sup>	1,51	1,74	150	110		
24	32	7,5 <sup>3)</sup>	18 <sup>3)</sup>	6,2	25	2,1 <sup>3)</sup>	1,8	7,0 <sup>3)</sup>	31	3000	94 :1	80	25	7,5	18	55	0,00015x10 <sup>-3</sup>	1,69	1,92	180	150		
24	24	8,5 <sup>3)</sup>	20 <sup>3)</sup>	8,2	21	1,9 <sup>3)</sup>	1,8	5,9 <sup>3)</sup>	27	3000	125 :1	80	21	8,5	20	55	0,00014x10 <sup>-3</sup>	1,69	1,92	180	150		
24	20	9,0 <sup>3)</sup>	20 <sup>3)</sup>	9,0	19	1,7 <sup>3)</sup>	1,7	5,0 <sup>3)</sup>	24	3000	150 :1	80	19	9,0	20	55	0,00010x10 <sup>-3</sup>	1,69	1,92	180	150		
24	17	10,1	20 <sup>3)</sup>	6,5	18	1,6	1,1	4,3 <sup>3)</sup>	22	3000	180 :1	80	18	10,5	20	55	0,00010x10 <sup>-3</sup>	1,32	1,55	180	150		GNM 2636A
24	14	10,5 <sup>3)</sup>	20 <sup>3)</sup>	7,8	15	1,4 <sup>3)</sup>	1,1	3,6 <sup>3)</sup>	19	3000	216 :1	80	15	10,5	20	55	0,00010x10 <sup>-3</sup>	1,32	1,55	180	150		
24	10	10,5 <sup>3)</sup>	20 <sup>3)</sup>	10,5	11	1,1 <sup>3)</sup>	1,1	2,8 <sup>3)</sup>	14	3000	293 :1	80	11	10,5	20	55	0,00006x10 <sup>-3</sup>	1,32	1,55	180	150		
24	8,5	10,5 <sup>3)</sup>	20 <sup>3)</sup>	10,5	9,4	0,99 <sup>3)</sup>	0,99	2,4 <sup>3)</sup>	12	3000	352 :1	80	9,4	10,5	20	55	0,00006x10 <sup>-3</sup>	1,32	1,55	180	150		
24	6,7	9,0 <sup>3)</sup>	18 <sup>3)</sup>	9,0	6,3	0,78 <sup>3)</sup>	0,78	1,8 <sup>3)</sup>	7,9	3000	450 :1	80	6,3	9,0	18	55	0,00006x10 <sup>-3</sup>	1,32	1,55	180	150		

Tolerances ± 10 %

Columns 3 and 13

Values are valid at operating temperature after run-in period.

Columns 5 and 8

Current values should not exceeded during operation with undulatory current (single way rectification) with harmonic portion above 5%.

Columns 4 and 9

Figures correspond with the gearbox load limitations. For high gear ratios the allowed currents may be lower than the motors rated current. If so, please the current has to be limited,e.g. through adjusting the servo controller.

Columns 14, 15 and 16

To avoid gear box overload do not exceed the mentioned values. For oscillating operation the mentioned limitations must be multiplied by 0,75.

<sup>1)</sup> values are reduced to motor shaft

<sup>2)</sup> middle of the shaft-extension

<sup>3)</sup> motor current must be limited to avoid excess of the mentioned value